

## 60CM FULLY INTEGRATED DISHWASHER



This dishwasher gives the perfect integrated solution, its triple 'A' class ratings ensure ultimate efficiency and thorough cleaning, whilst the programme options available suit every circumstance.

- **Auto Programme** - no need to decide what programme is the most suitable for the dishes, let the dishwasher decide for you. Using a sensor the dishwasher will modify the time, temperature, water consumption and energy based on the soiling level. The temperatures range from 45°C to 70°C - ideal for the most delicate of glassware to the dirtiest of dishes
- **Active Drying** - for perfect drying results, the active drying system aids the natural circulation of moist air through a condensing unit
- **LED Display** - indicates the amount of time of the programme remaining and allows the start time of the programme to be delayed so the dishwasher can be run when electricity rates are cheaper
- **'AAA' rated** - an 'A' rating for wash performance, drying performance and energy efficiency, giving you peace of mind that your dishwasher is giving top rate wash & dry results in an energy efficient way
- **Low water consumption** - just 14 litre water consumption



## FULLY INTEGRATED DISHWASHER

### FEATURES

- 12 place settings
- LED display
- Height adjustable full load
- 4 folding cup shelves
- 2 foldable plate racks
- Grey coloured baskets
- Active drying
- 47dB(A)
- 14 litres water consumption

### PROGRAMMES & OPTIONS

- Quick (30 minutes)
- Intensive 70°C
- Auto 45 - 70°C
- Bio 50°C with prewash
- Glasscare 45°C
- Rinse & hold
- Plate warmer
- Delay start timer
- Time to programme end
- Half load option

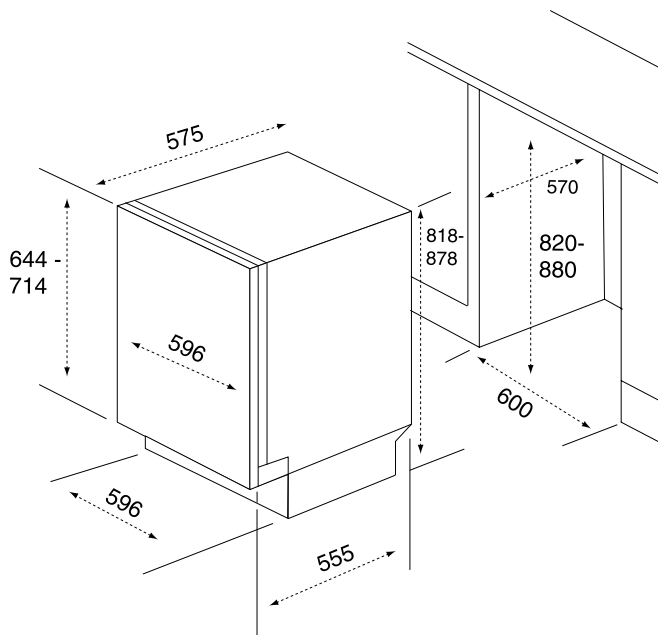

FEATURES	
Capacity (number of IEC place settings)	12
Design	Fully integrated
Auto half load	■
Electronic controls	■
LED programme progress indicator	■
Time to programme end display	■
End of programme indicator	■
End of programme alarm	■
Delay start	■
Salt refill indicator	■
Rinse aid refill indicator	■
Half load option	■
Number of programmes	7
Number of temperature options	4
INTERIOR	
Upper basket height	Quick lift
Cup shelves	4 foldable
Lower basket plate racks	2 foldable
Basket handles	Delta silver
Cutlery basket	Delta silver
Automatic rinse aid dispenser	■
Automatic detergent dispenser	■
Anti flood device	■
Drying with hidden heater	Active
Stainless steel interior	■
INSTALLATION FEATURES	
Cold water fill	■
Water pressure min / max (psi)	0.5 / 8.0
Equipoise door	■
Double fulcrum hinge	-
Drawer-line adjustment	-
Worktop steam protection	Metal
Top & side fixing brackets	■
Recessed plinth	■
Feet - 3 (front adjustment block)	■
ENERGY EFFICIENCY	
Energy efficiency class	A
Energy consumption (kWh)	1.05
Wash performance	A
Drying performance	A
Noise, IEC 704-3 (dB(A))	47
Programme time (mins)	160
Water consumption (litres/cycle)	14
Average annual energy consumption (kWh/year)	231
Average annual water consumption (litres/year)	3080
ELECTRICAL CONNECTION	
Connected load (kW)	2.2
Fuse rating (A)	13
APPLIANCE DIMENSIONS	
Height (mm)	818 - 878
Width (mm)	596
Depth (mm)	555
Net weight (kg)	36.9
FURNITURE DOOR DIMENSIONS	
Height (mm)	644 - 714
Width (mm)	596
Depth (mm)	2.0 - 7.5
PACKAGING DIMENSIONS	
Height (mm)	902
Width (mm)	635
Depth (mm)	680
Gross weight (kg)	38.6