

## 60cm fully-integrated dishwasher.



Packed with features which ensure the quiet, quick, and thorough cleaning and drying of all your crockery and cutlery, this dishwasher is the perfect built in solution.

- **Night cycle** - the specially designed night cycle programme lowers the noise level to just 39dB for the duration of the cycle, making it the quietest programme in the world
- **Quick 55°C** - perfect for a full load of lightly soiled dishes. This programme is just 55 minutes but still gives an 'A' rated wash programme
- **Auto programme** - the auto programme will adjust the duration, temperature, water consumption and pressure depending on the contents and soiling level of the load
- **Multitab** - to ensure perfect results whatever the detergent type, the multitab option modifies the programme ensuring that all elements of the tablet are released when needed
- **Extra spray arm** located on the ceiling of the dishwasher tub provides better rinsing and works with the cutlery tray suitable for knives, spatulas and ladles
- **Active drying** - for perfect drying results the active drying system aids the natural circulation of moist air through a condensing unit



## 60cm fully-integrated dishwasher

### FEATURES

- Fully integrated
- 12 place settings
- 8 programmes
- Intensive 70°C
- Night cycle
- Quick 55°C
- Auto 45°C-70°C
- Eat Load Go 60°C
- Bio 50°C
- Glass 45°C
- Rinse & hold
- Delay start 1 -19 hours
- 41dB
- 12 litres
- Active drying
- Cutlery tray
- Multitab option
- Auto half load
- Extra spray arm
- Operation beam
- AAA rated

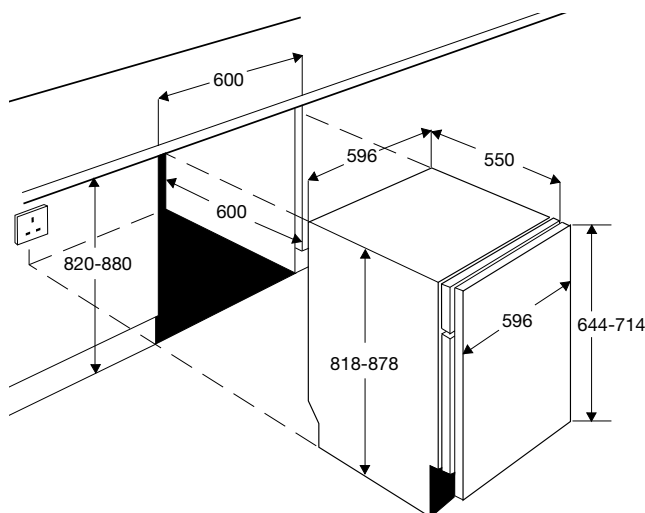

<sup>1</sup> Energy consumption is stated in kWh per standard test cycle, using cold water fill.

Actual consumption will depend on how the appliance is used

<sup>2</sup> Estimated annual consumption based on 220 washing cycles

<sup>3</sup> Models with an 'A' rated classification offer a higher performance than those with a 'G' rating

<sup>4</sup> Time taken for a standard test cycle, using cold water fill

### PERFORMANCE

Capacity (number of IEC place settings)	12
Number of programmes	8
Number of temperatures	5
Auto half load	■
Automatic 45°C - 70°C programme	■
Night cycle	■
Quick 55	■
Bio 50°C with prerinse programme	■
Glass programme	■
Eat-Load-Go programme	■
Plate warmer	-
Rinse hold programme	■
Delay start option	■
Multi-tab option	■
Drying system	Active

### FEATURES

LCD display with digital push button controls	-
Programme selection buttons	■
LED display with remaining time	■
LED programme progress indicators	-
Height adjustable upper basket	■
Foldable cup shelves	■
Long stem wine glass holder	■
Adjustable glass support	■
Tall lower basket, front basket handles	■
Foldable bottom plate supports	■
Cutlery basket	Fold out
Double fulcrum hinge	■
Interior light	■
3rd spray arm	■

### REASSURANCE

Aqua control	■
Anti flood device (other)	Floating switch
Worktop steam protection	Metal
Drawer-line adjustment	-
Top & side fixing brackets	■
Red beam - spot light	■
End of programme audible buzzer	■
Water softener	■
Salt refill indicator	■
Rinse aid refill indicator	■

### ENERGY EFFICIENCY

Energy efficiency class <sup>3</sup>	A
Energy consumption (kWh) <sup>1</sup>	1.05
Wash performance <sup>3</sup>	A
Water consumption (litres/cycle)	12
Drying performance <sup>3</sup>	A
Noise to IEC 704-3 (dB(A))	41
Programme time (mins) <sup>4</sup>	160
Average annual energy consumption (kWh/year) <sup>2</sup>	231
Average annual water consumption (litres/year) <sup>2</sup>	2640
Declared programme	Bio 50°C with prerinse

### APPLIANCE DIMENSIONS

Height (mm)	818
Width (mm)	596
Depth (mm)	550
Net weight (kg)	41.5

### BUILT-IN DIMENSIONS

Height (mm)	820 / 880
Width (mm)	600
Depth (mm)	600

### PACKAGING DIMENSIONS

Height (mm)	902
Width (mm)	650
Depth (mm)	680
Gross weight (kg)	43

### FURNITURE DOOR DIMENSIONS

Height (mm)	644 - 714
Width (mm)	596
Weight net / gross (kg)	2.0 / 7.5

### OTHER

Voltage / frequency (volts / Hz)	220 / 240
Connected load (kW)	2.2
Fuse rating	13
Water pressure min / max (bar)	0.5 / 8
Water pressure min / max (Mpa)	0.05 / 0.8
Cold water fill	Cold
Electrical/equipment safety regulations	■
Radio/television interference suppression	■
Operation and installation instructions supplied	■