

60cm fully-integrated dishwasher.



Packed with features which ensure the quiet, quick and thorough cleaning and drying of all your crockery and cutlery, this dishwasher is the perfect built-in solution.

- **Auto programme** - the auto programme will adjust the duration, temperature, water consumption and pressure depending on the contents and soiling level of the load
- **Multitab** - to ensure perfect results whatever the detergent type, the multitab option modifies the programme ensuring that all elements of the tablet are released when needed
- **Extra spray arm** located on the ceiling of the dishwasher tub provides better rinsing and works with the cutlery tray suitable for knives, spatulas and ladles
- **Active drying** - for perfect drying results the active drying system aids the natural circulation of moist air through a condensing unit



60cm fully-integrated dishwasher

FEATURES

- Fully integrated
- 12 place settings
- 5 programmes
- Intensive 70°C
- Auto 45°C-70°C
- Eat Load Go 60°C
- Bio 50°C
- Rinse & hold
- 1-19 hours time delay
- 45dB
- 12 litre consumption
- Active drying
- Easy lift height adjustable basket
- Multitab
- Auto half load
- Extra spray arm
- Aqua control
- Operation beam
- AAA rated

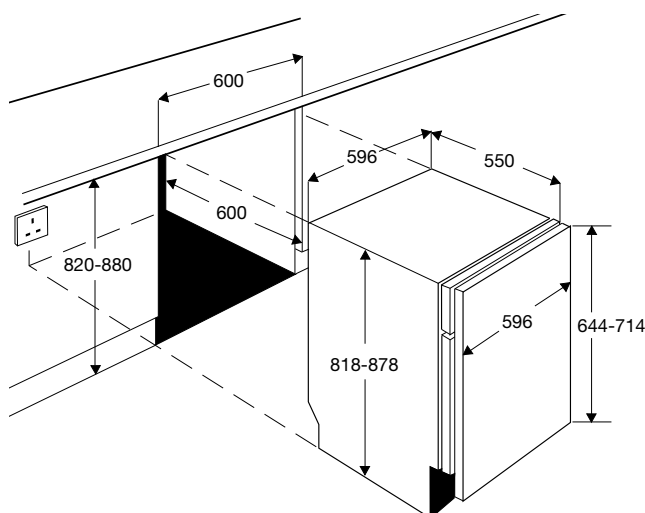

¹ Energy consumption is stated in kWh per standard test cycle, using cold water fill.

Actual consumption will depend on how the appliance is used

² Estimated annual consumption based on 220 washing cycles

³ Models with an 'A' rated classification offer a higher performance than those with a 'G' rating

⁴ Time taken for a standard test cycle, using cold water fill

PERFORMANCE	
Capacity (number of IEC place settings)	12
Number of programmes	5
Number of temperatures	4
Auto half load	■
Automatic 45°C - 70°C programme	■
Night cycle	-
Quick 55	-
Bio 50°C with prerinse programme	■
Glass programme	-
Eat-Load-Go programme	■
Plate warmer	-
Rinse hold programme	■
Delay start option	■
Multi-tab option	■
Drying system	Active
FEATURES	
LCD display with digital push button controls	-
Programme selection buttons	■
LED display with remaining time	■
LED programme progress indicators	-
Height adjustable upper basket	■
Foldable cup shelves	■
Long stem wine glass holder	■
Adjustable glass support	■
Tall lower basket, front basket handles	■
Foldable bottom plate supports	■
Cutlery basket	Fold out
Double fulcrum hinge	■
Interior light	-
3rd spray arm	■
REASSURANCE	
Aqua control	■
Anti flood device (other)	Floating switch
Worktop steam protection	Metal
Drawer-line adjustment	-
Top & side fixing brackets	■
Red beam - spot light	■
End of programme audible buzzer	■
Water softener	■
Salt refill indicator	■
Rinse aid refill indicator	■
ENERGY EFFICIENCY	
Energy efficiency class ³	A
Energy consumption (kWh) ¹	1.05
Wash performance ³	A
Water consumption (litres/cycle)	12
Drying performance ³	A
Noise to IEC 704-3 (dB(A))	45
Programme time (mins) ⁴	160
Average annual energy consumption (kWh/year) ²	231
Average annual water consumption (litres/year) ²	2640
Declared programme	Bio 50°C with prerinse
APPLIANCE DIMENSIONS	
Height (mm)	818
Width (mm)	596
Depth (mm)	550
Net weight (kg)	38.5
BUILT-IN DIMENSIONS	
Height (mm)	820 / 880
Width (mm)	600
Depth (mm)	600
PACKAGING DIMENSIONS	
Height (mm)	902
Width (mm)	650
Depth (mm)	680
Gross weight (kg)	40
FURNITURE DOOR DIMENSIONS	
Height (mm)	644 - 714
Width (mm)	596
Weight net / gross (kg)	2.0 / 7.5
OTHER	
Voltage / frequency (volts / Hz)	220 / 240
Connected load (kW)	2.2
Fuse rating	13
Water pressure min / max (bar)	0.5 / 8
Water pressure min / max (Mpa)	0.05 / 0.8
Cold water fill	Cold
Electrical/equipment safety regulations	■
Radio/television interference suppression	■
Operation and installation instructions supplied	■